

MX0400

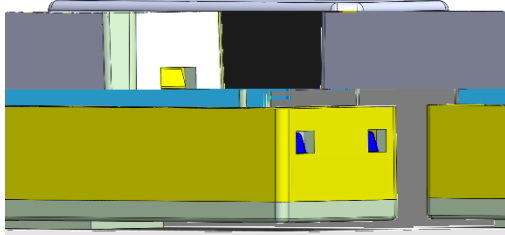

Description

Applications

Features

LIGHT

Schematic

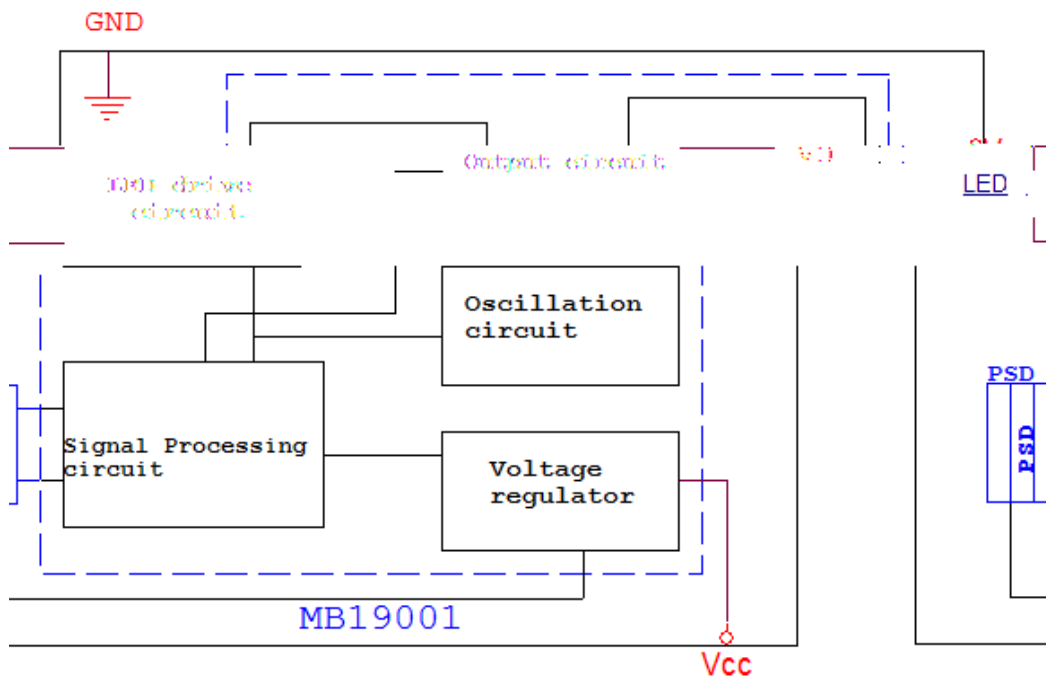

Outline

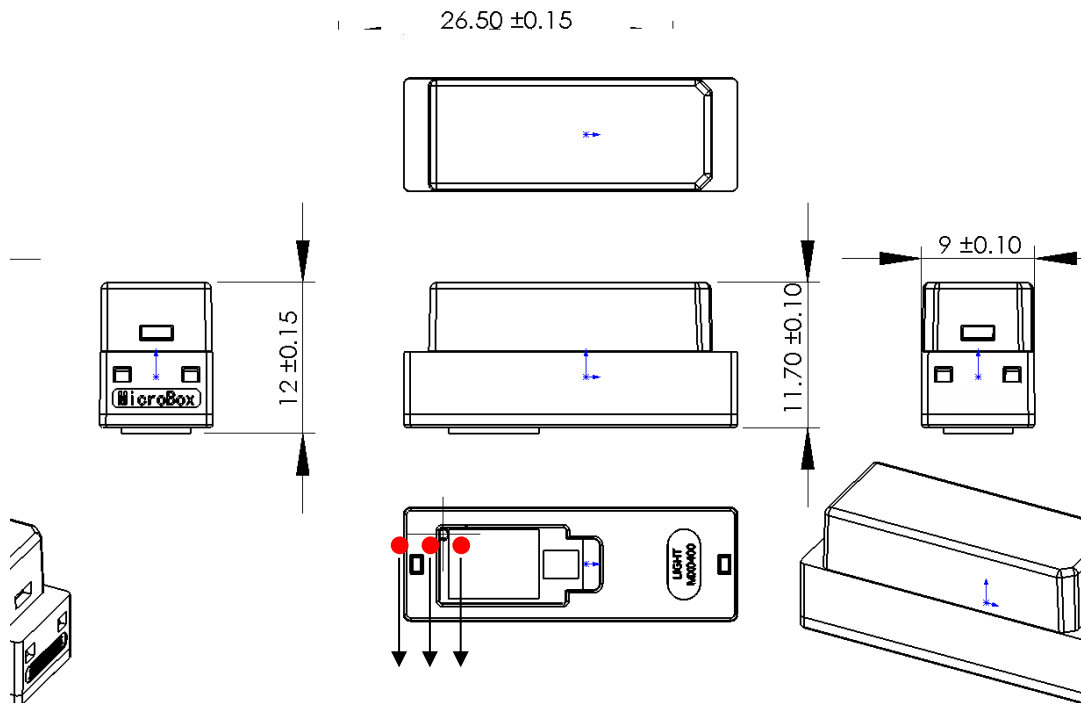

LIGHT

pin	Note
Vcc	4.5V-5.5V
GND	NA
Vo	0-2.5V

Absolute maximum ratings

Supply voltage	Vcc	0 to +6.8	V
Output terminal Voltage	Vo	-0.3 to +0.3	V
Operating temperature	Topr	-10 to +60	°C
Storage temperature	Tstg	-40 to +70	°C

Operating supply voltage

Vcc	4.5 to 5.5	V

Electro-optical characteristics

Measuring distance range		NA	15		150	mm
Output terminal Voltage	Vo	L=20mm		1.81		V
Output voltage difference		15mm-150mm	0.94		2.1	V
Average supply current	Icc	L=150mm		10		mA

Timing charting

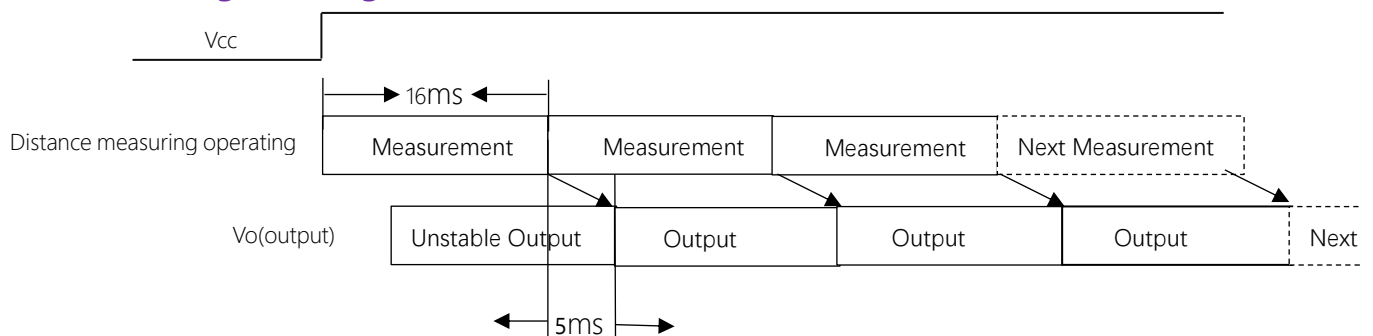

Output distance characteristics

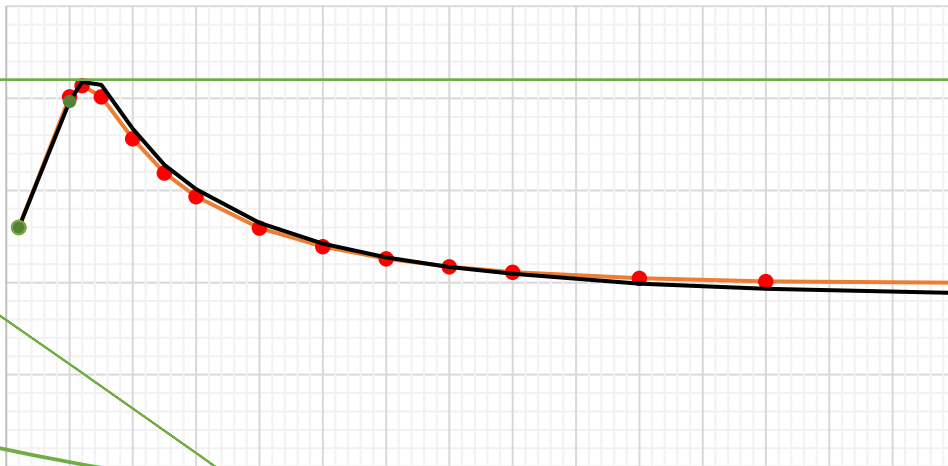
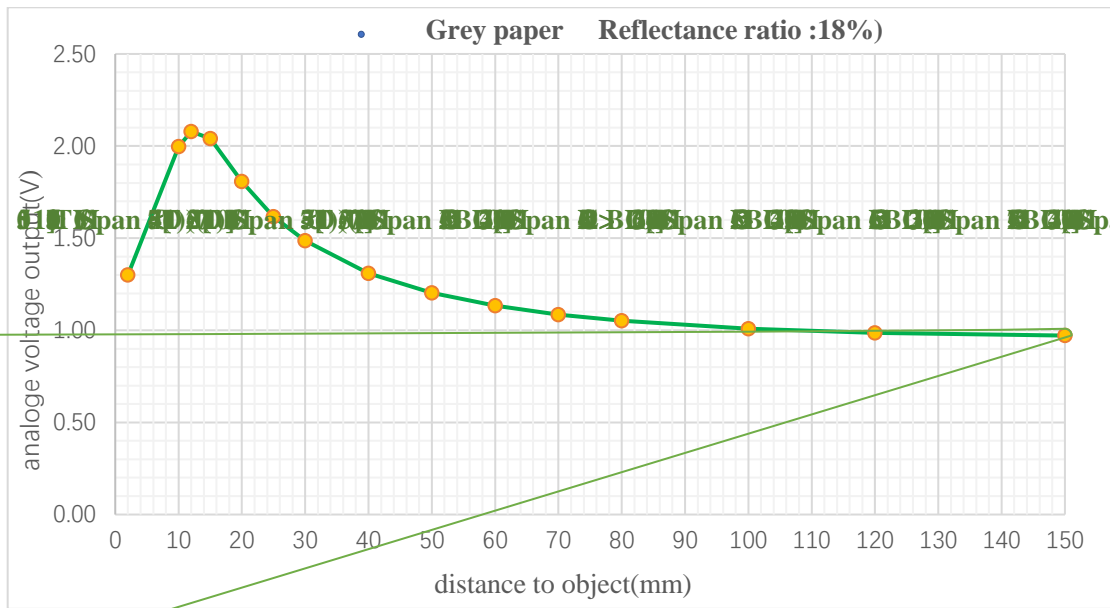



Models for the optics

- Elements of this device shall be kept clean'. (here are cases that dust, water or oil and so on deteriorate the

