

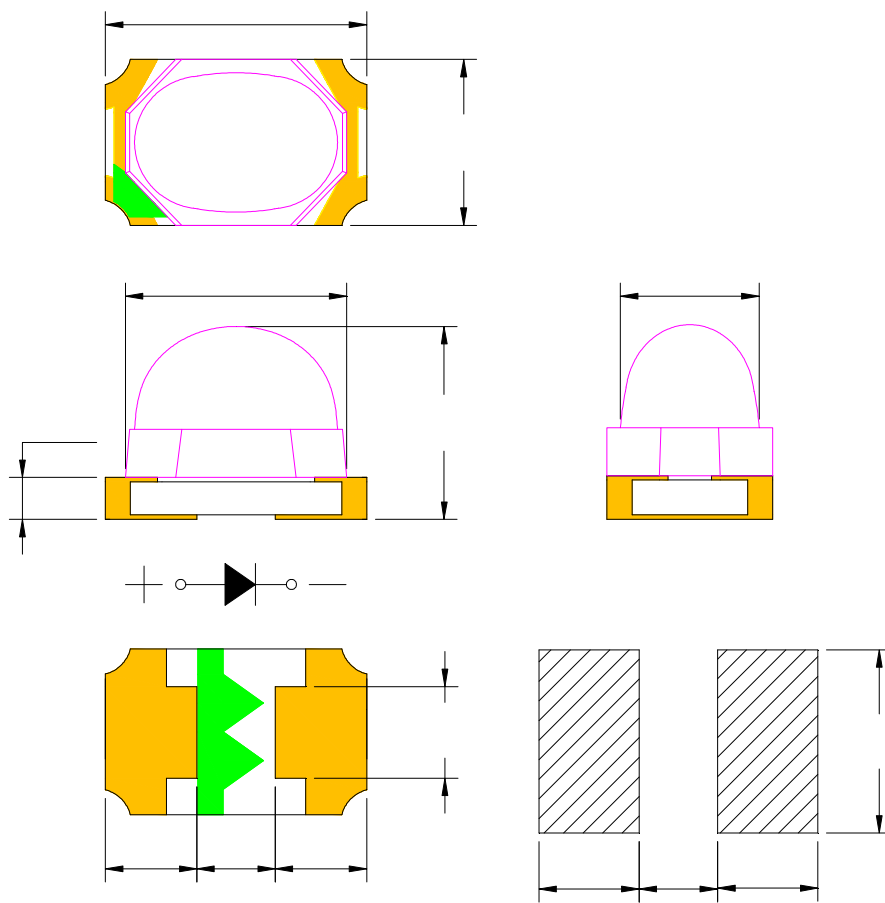

## Features

## Package Dimension





Notes:

### Absolute Maximum Ratings at Ta=25

1. Storage and operating:

2. Peak Forward Current:

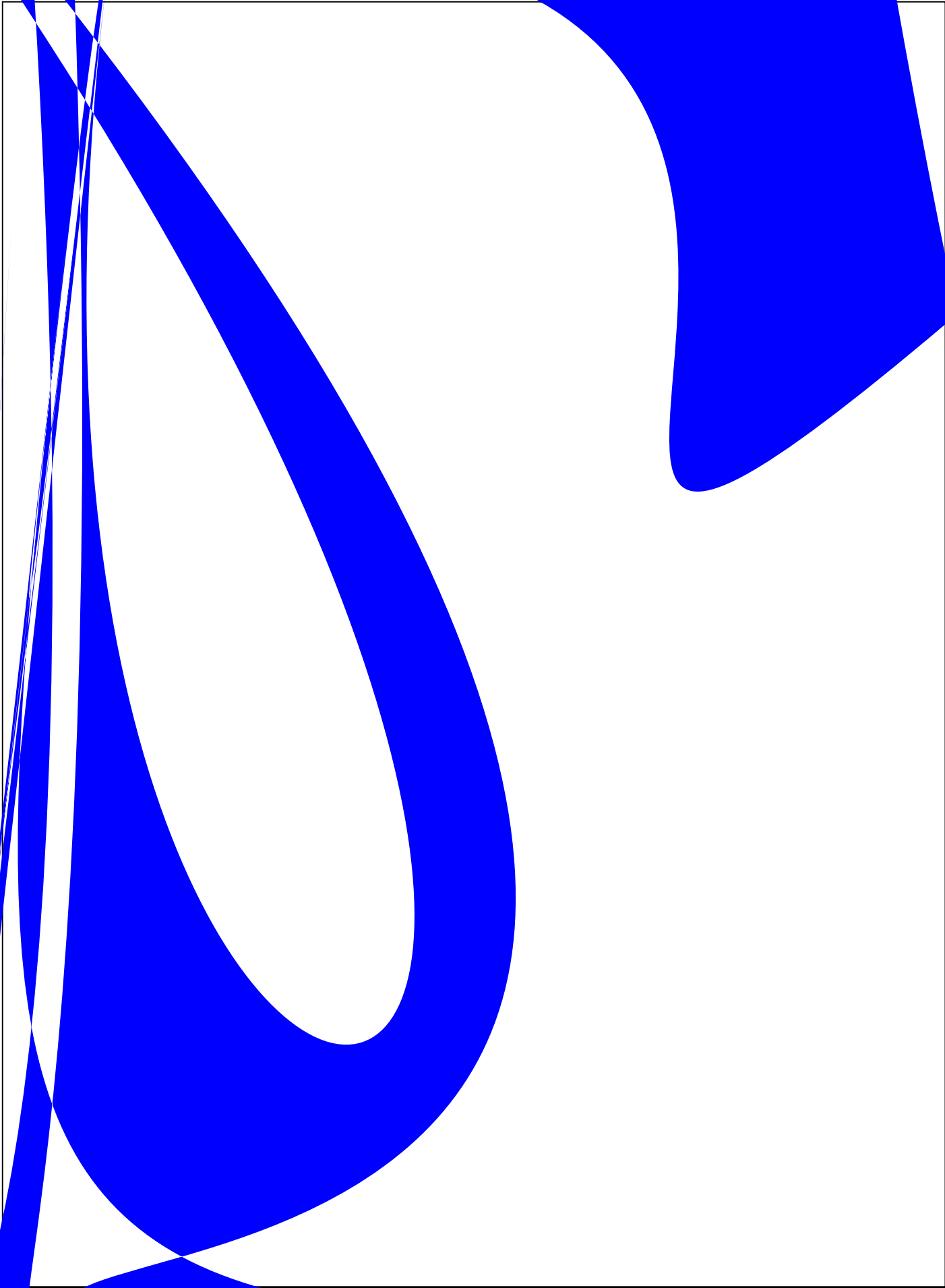
3. Caution in ESD:



LIGHT

LIGHT ELECTRONICS CO., LTD.

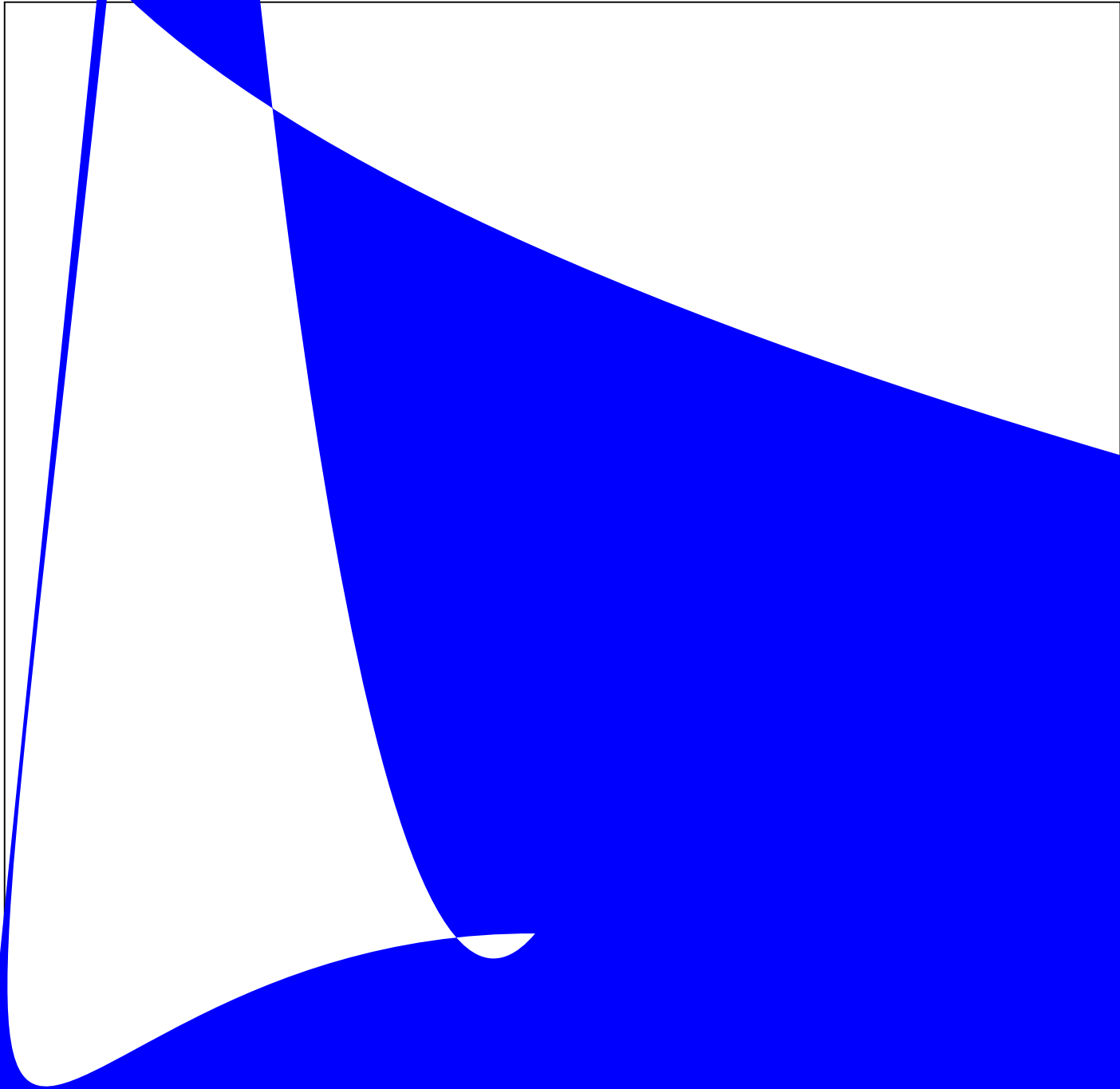

L





**Note:**

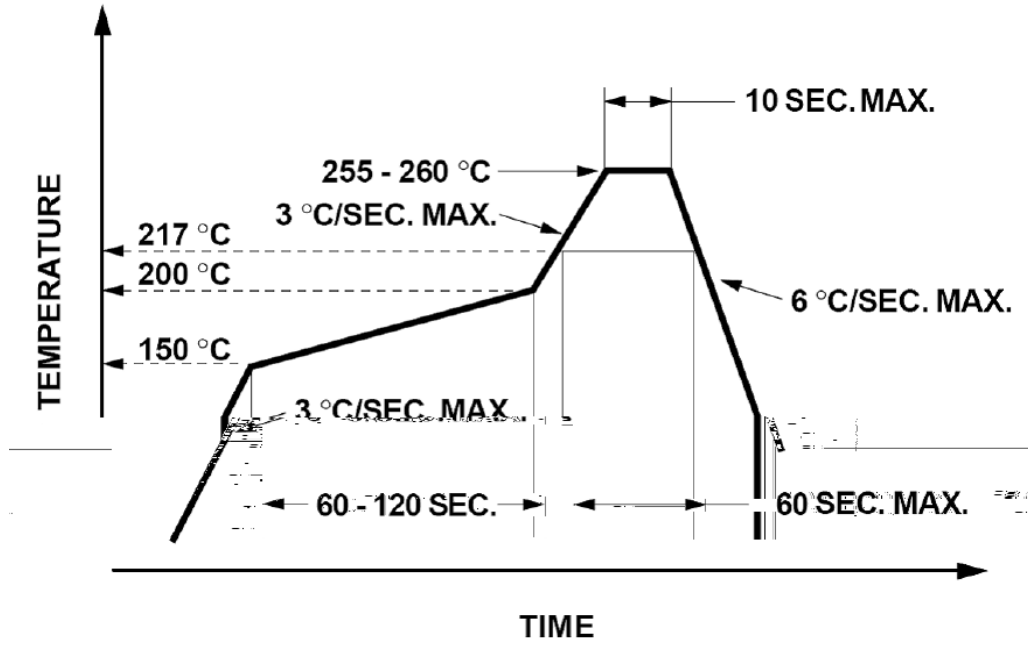

°C

