

## LG-05IR3C94B-5118E

### DATA SHEET

SPEC. NO. : SZ21011201  
DATE : 2021/01/12  
REV. : A/0

Approved By:

Checked By:

Prepared By:

## Features

- ◆ Pb free product    RoHS compliant
- ◆ Low power consumption, High efficiency
- ◆ General purpose leads
- ◆ Reliable and rugged
- ◆ Long life    solid state reliability
- ◆ Radiant angle: 15 °

## Package Dimension

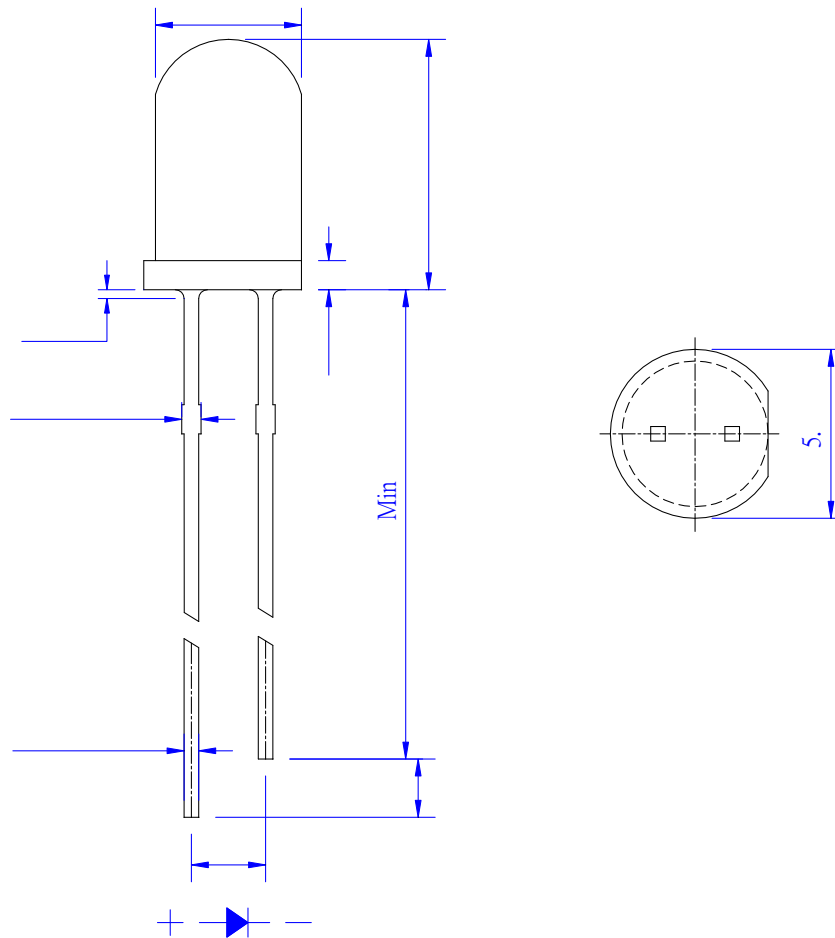

Part NO.	Chip Material	Lens Color
LG-05IR3C94B-5118E	AlGaAs	Water Clear

### Notes:

1. All dimensions are in millimeters.
2. Tolerance is  $\pm 0.20\text{mm}$  unless otherwise noted.
3. Protruded resin under flange is 1.0mm max.
4. Lead spacing is measured where the leads emerge from the package.
5. Specifications are subject to change without notice.

## Absolute Maximum Ratings at Ta=25°C

Parameter	MAX.	Unit
Power Dissipation	75	mW
Continuous Forward Current	50	mA
Peak Forward Current*3	1.0	A
Reverse Voltage	5	V
Operating Temperature	-40 to + 85	
Storage Temperature	-40°C to + 100°C	
Lead Soldering Temperature [2mm From Body]	260 for 3 Seconds	
Lead Soldering Temperature [5mm From Body]	260 for 5 Seconds	

### 1. Storage

The storage ambient for the LEDs should not exceed 30 °C temperature or 70% relative humidity.

It is recommended that LEDs out of their original packaging are used within three months.

For extended storage out of their original packaging, it is recommended that the LEDs be stored in a sealed container with appropriate desiccant or in desiccators with nitrogen ambient.

### 2. Precautions in handling:

- When soldering, leave 2mm of minimum clearance from the resin to the soldering point.
- Dipping the resin to solder must be avoided.
- Correcting the soldered position after soldering must be avoided.
- In soldering, do not apply any stress to the lead frame particularly when heated.
- When forming a lead, make sure not to apply any stress inside the resin.
- Lead forming must be done before soldering.
- It is necessary to cut the lead frame at normal temperature.

### 3. Peak Forward Current:

Condition for is IFP pulse : 0.1ms and duty /100.



LIG

LIGHT

